

INSTALLATION INSTRUCTIONS - TIMBER FRAME SPINNER

STEP 1

Screw square plate onto **BOTTOM** face of spinner body, making sure the holes align.

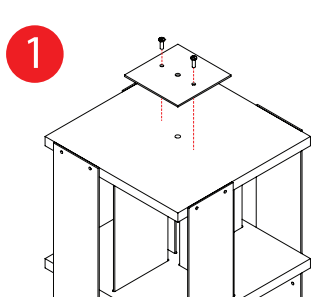

STEP 2

Flip timber frame upside down.

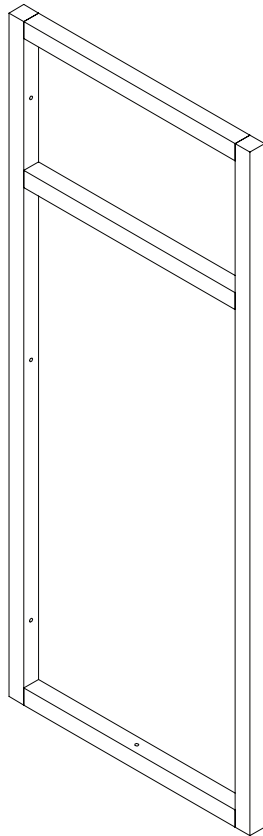

STEP 3

Place washer assembly on top of metal plate. Assembly is large washer; bearing with small locator washer in the centre then large washer. Ensure holes align

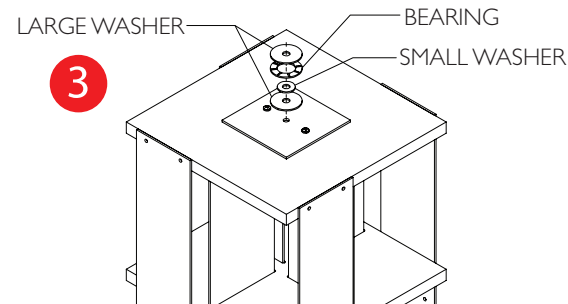

STEP 4

Place spinner body and washers into the timber frame, make sure all holes align

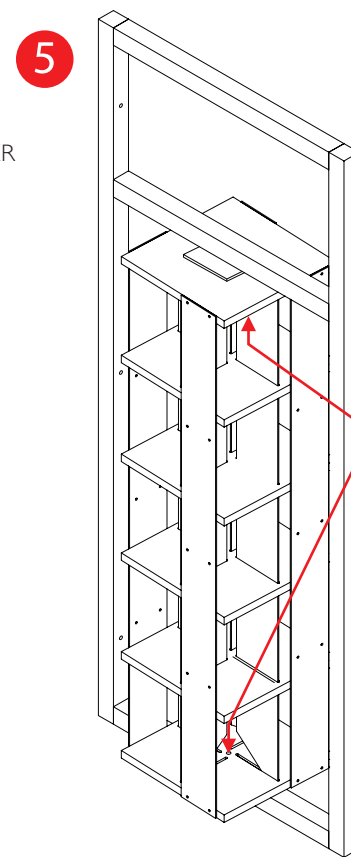

STEP 5

Insert pin in top and bottom, then tip the unit onto its side

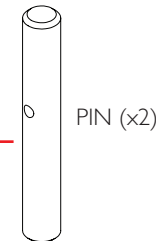

STEP 6

Slide spinner body all the way towards the bottom (where the washers are) allowing space at the top to place the split pin into the hole. Ensure the hole and split pin are located in between the top of the spinner bod and the timber frame

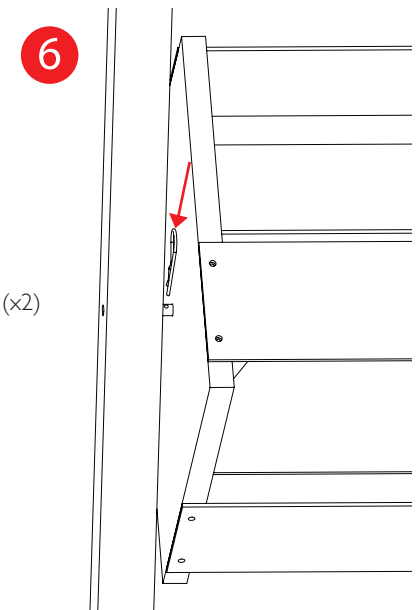

FINAL STEP

Turn the unit up the correct way